

REVISIONS				
ZONE	REV.	DESCRIPTION	DATE	APPROVED
	B	Measure changed	18.1.2016	

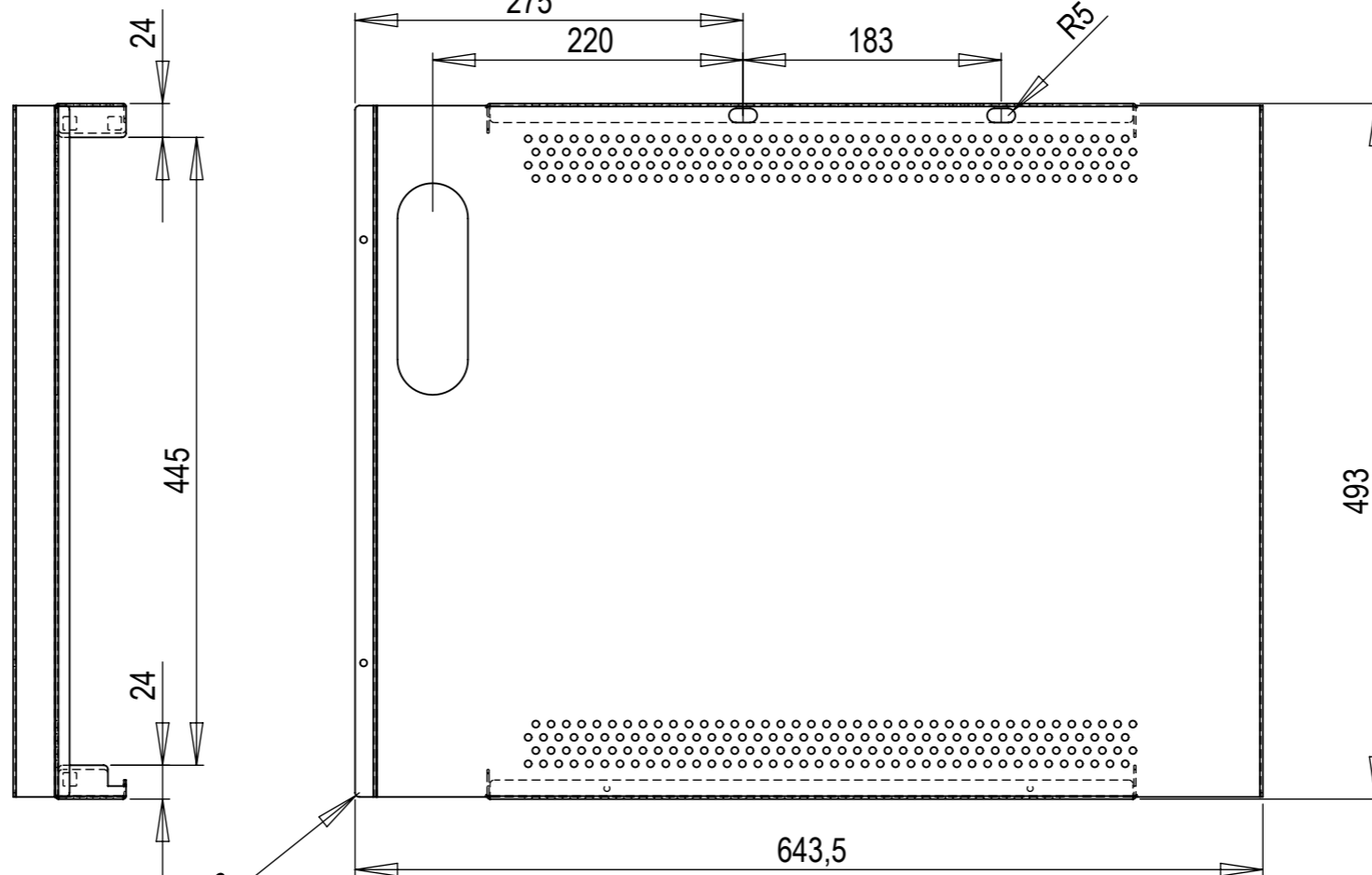
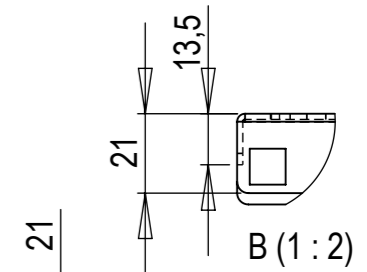
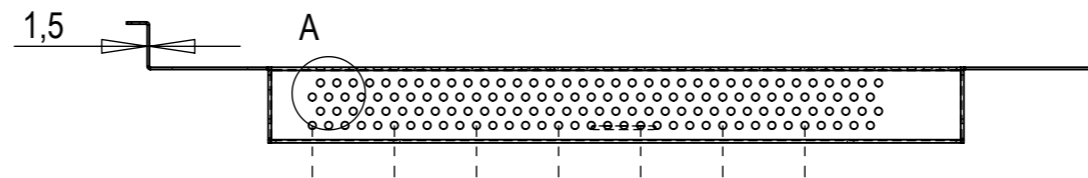
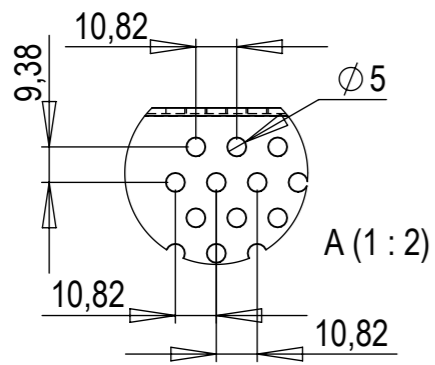

Ⓟ 451

21

21

Ⓞ C

R3  
all outside corners

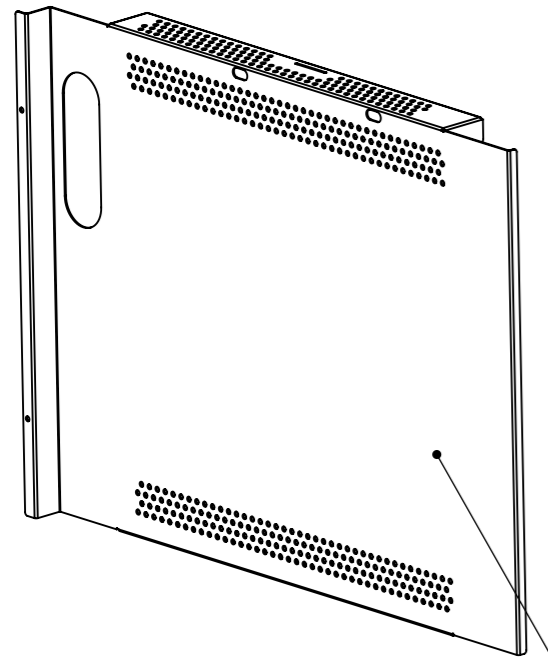
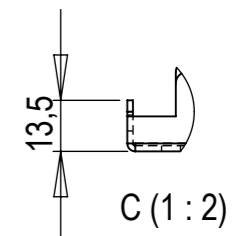
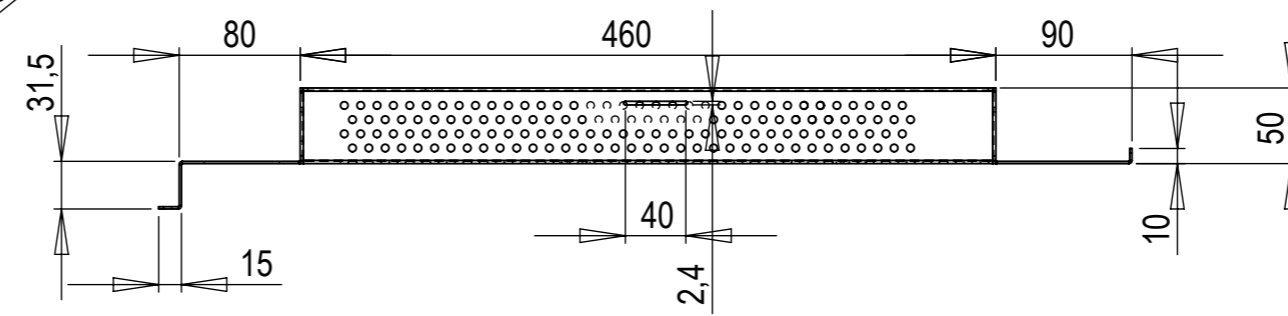

Visible side

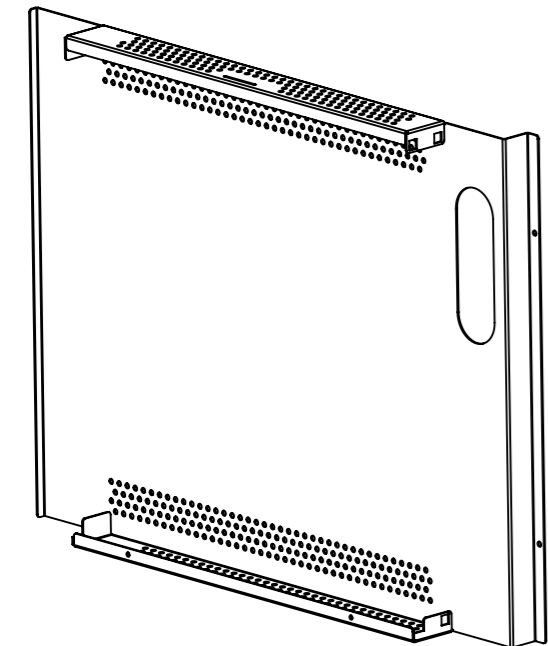

UNLESS OTHERWISE SPECIFIED: DIMENSIONS ARE IN MILLIMETERS		FINISH: Powder paint, all surfaces RAL7040 Thickness min 50um		DEBUR AND BREAK SHARP EDGES		DO NOT SCALE DRAWING		REVISION B	
TOLERANCES: ISO 2768mK									
	NAME	SIGNATURE	DATE			TITLE: <b>Enclosure Base, Right</b>			
DRAWN	MPI		7.12.2015						
CHK'D	MPI		18.1.2016						
APPV'D	-		-						
MFG									
Q.A						MATERIAL: DC01 Am s=1,5 mm		DWG NO. <b>32739</b>	
File:		Navaia_Enclosure_Base		Prod. code: -		SCALE:1:5		SHEET 1 OF 4	
								A3	

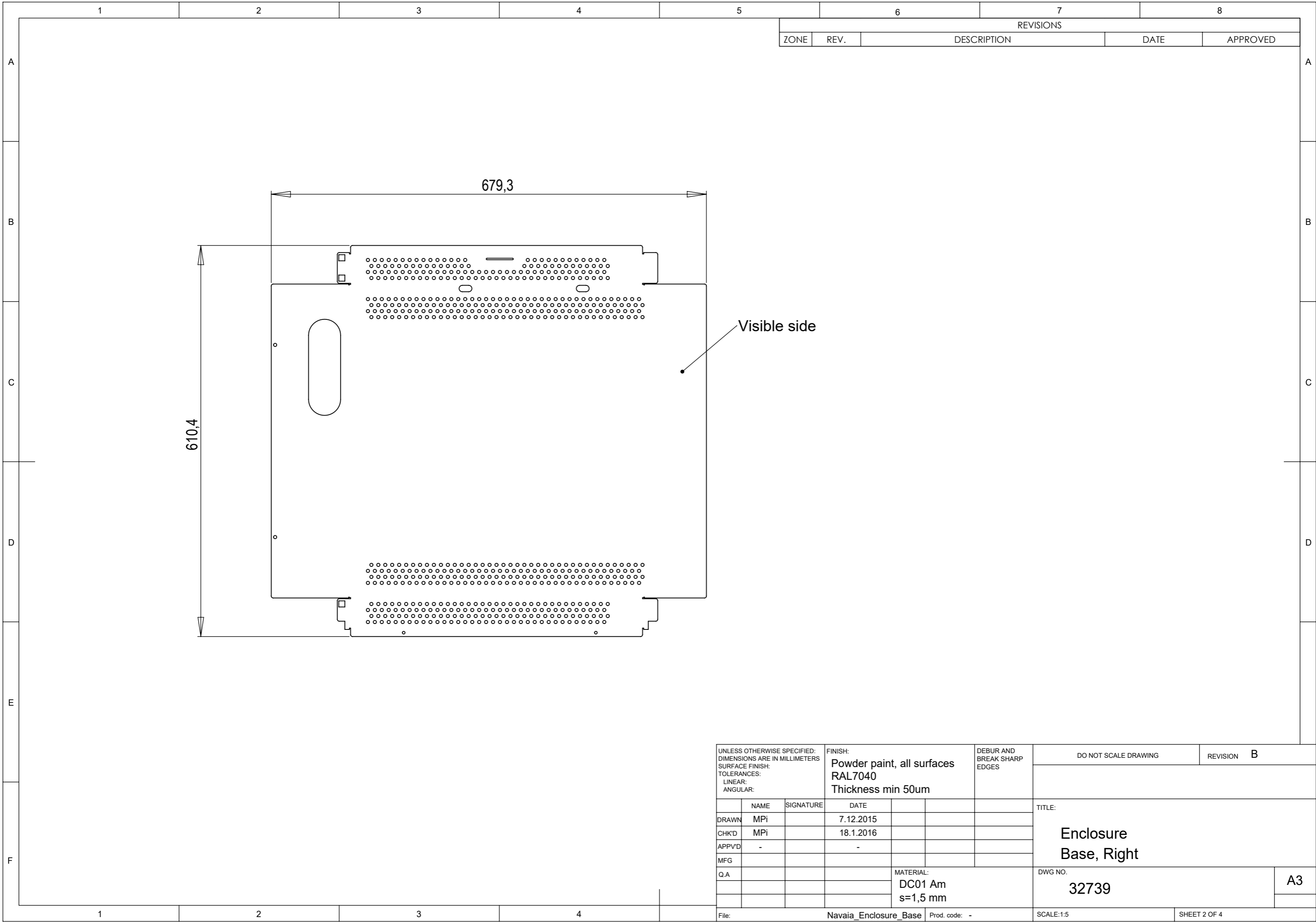

REVISIONS				
ZONE	REV.	DESCRIPTION	DATE	APPROVED

UNLESS OTHERWISE SPECIFIED: DIMENSIONS ARE IN MILLIMETERS		FINISH: Powder paint, all surfaces RAL7040 Thickness min 50um		DEBUR AND BREAK SHARP EDGES		DO NOT SCALE DRAWING		REVISION <b>B</b>	
DRAWN	MPI	SIGNATURE	DATE			TITLE: <b>Enclosure Base, Right</b>			
CHK'D	MPI		18.1.2016						
APPV'D	-		-						
MFG									
Q.A									
				MATERIAL: DC01 Am s=1,5 mm		DWG NO. <b>32739</b>		A3	
File:		Navaia_Enclosure_Base		Prod. code: -		SCALE:1:5		SHEET 2 OF 4	

ITEM NO.	PART NAME	PRODUCT CODE	QTY.
1	Equipment_enclosure_base		1
2	CLS-M3-1		2

REVISIONS				
ZONE	REV.	DESCRIPTION	DATE	APPROVED

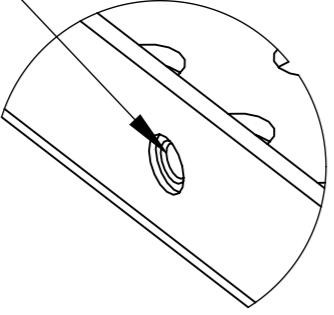
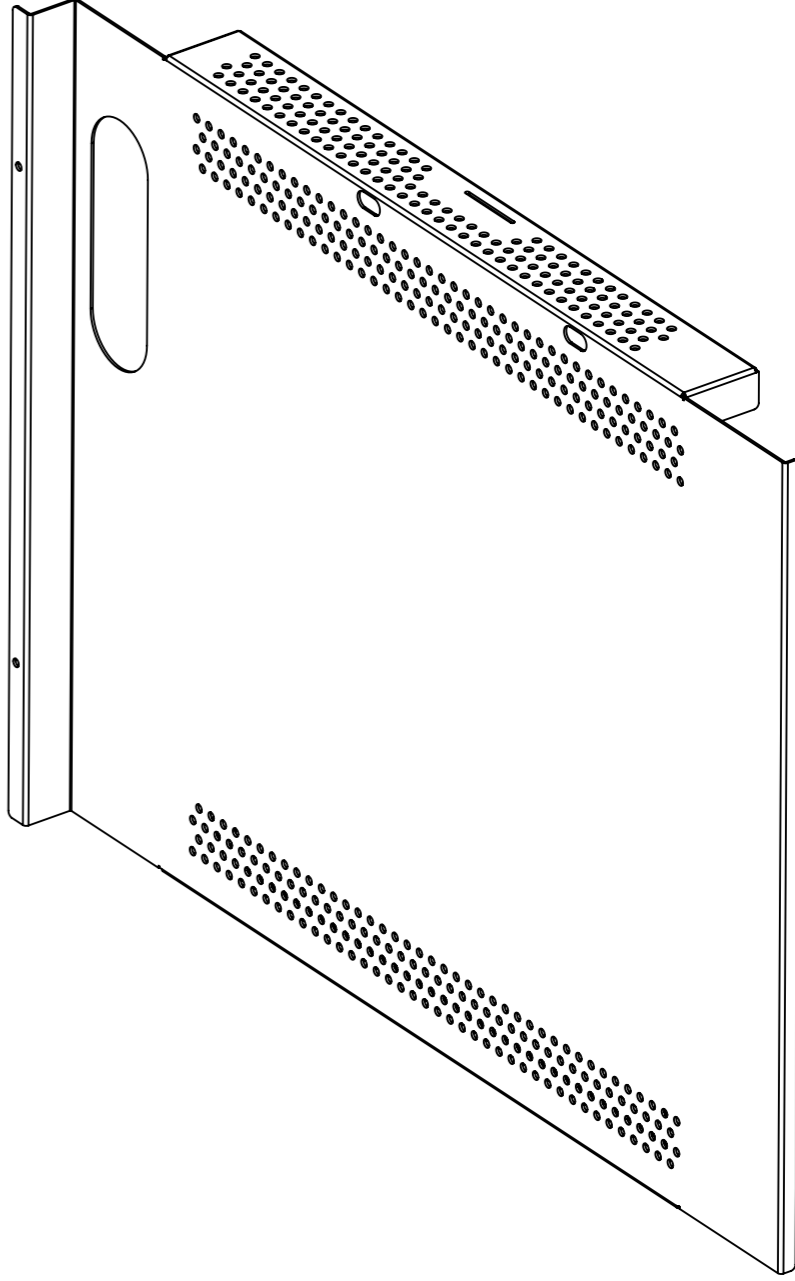
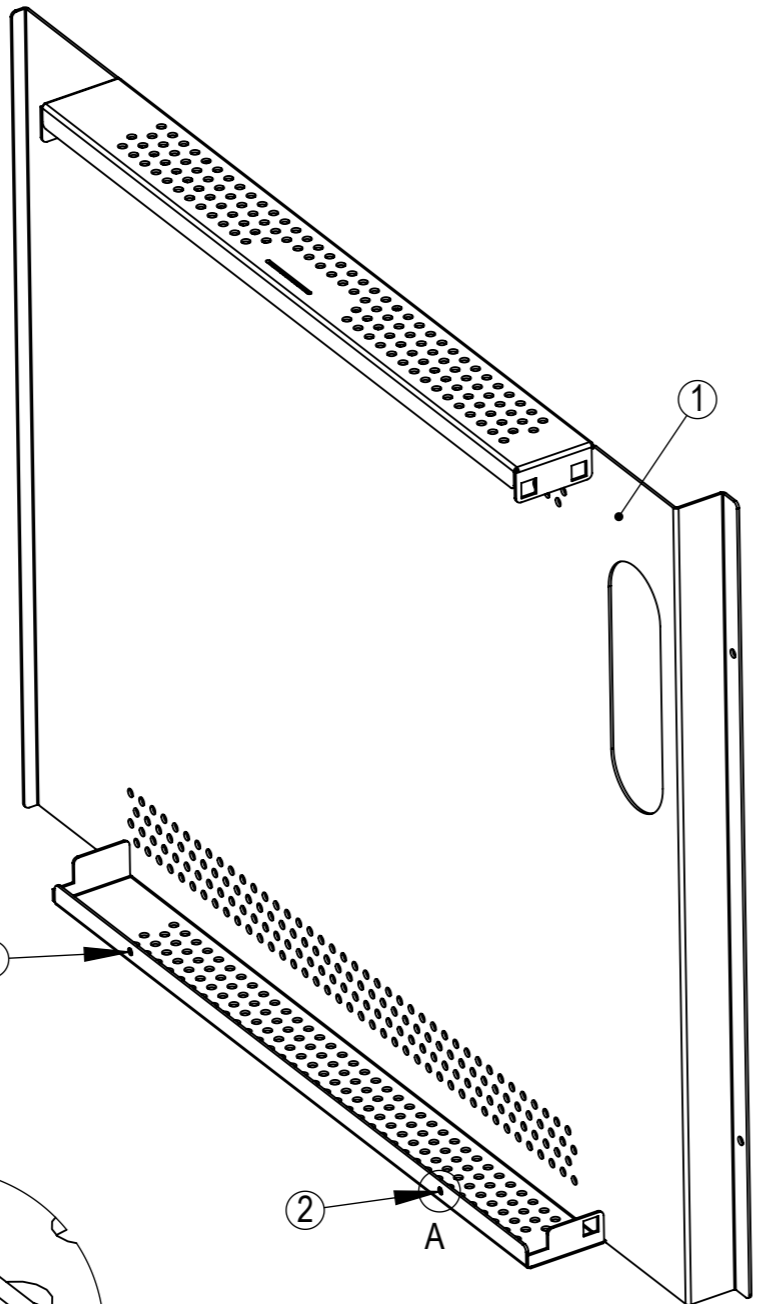

UNLESS OTHERWISE SPECIFIED: DIMENSIONS ARE IN MILLIMETERS		FINISH: Powder paint, all surfaces RAL7040 Thickness min 50um		DEBUR AND BREAK SHARP EDGES		DO NOT SCALE DRAWING		REVISION B	
SURFACE FINISH:		DATE				TITLE:			
TOLERANCES:		18.1.2016				Enclosure Base, Right			
LINEAR:									
ANGULAR:						DWG NO.		A3	
				MATERIAL:		32739			
				DC01 Am s=1,5 mm		SCALE:1:5		SHEET 3 OF 4	
DRAWN MPI		SIGNATURE		DATE		File:		Navaia_Enclosure_Base Prod. code: -	
CHK'D MPI									
APPV'D -									
MFG									
Q.A									

REVISIONS				
ZONE	REV.	DESCRIPTION	DATE	APPROVED

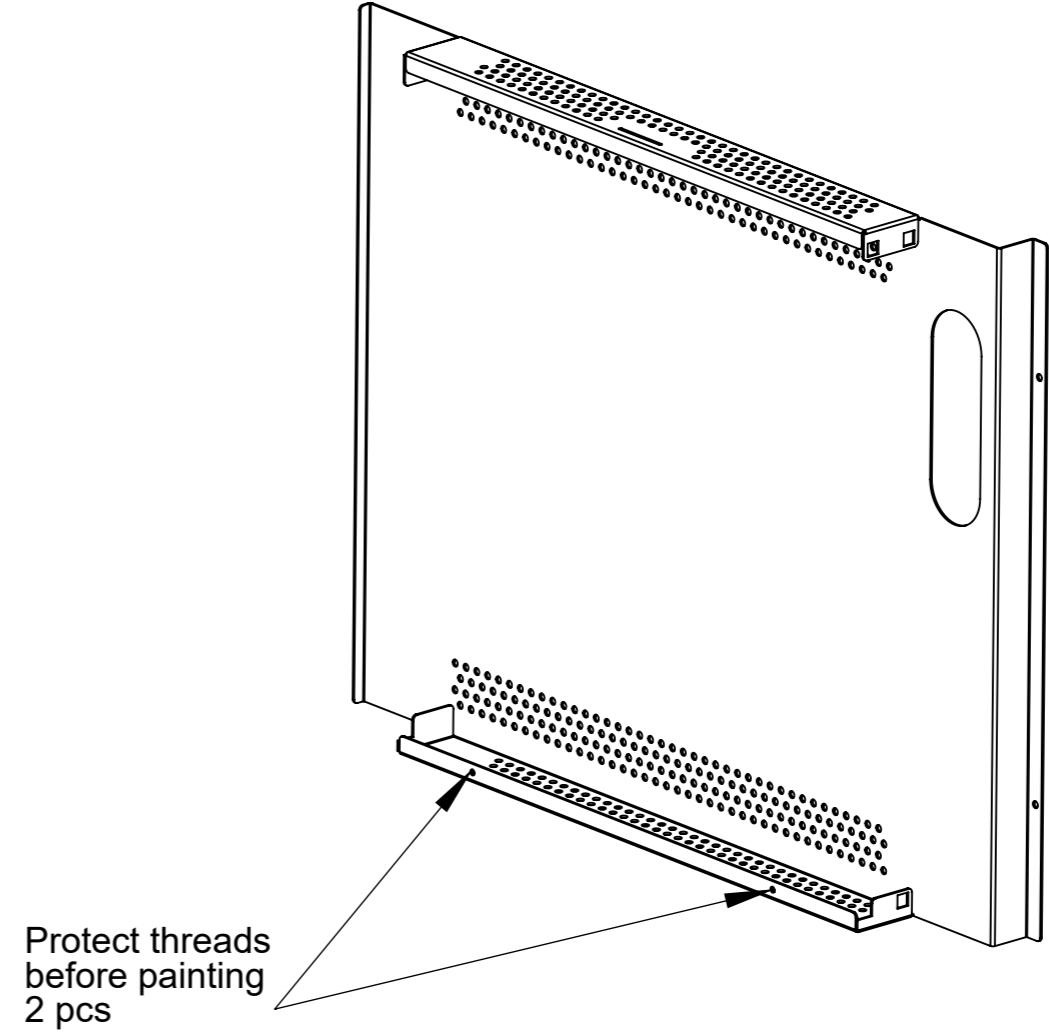
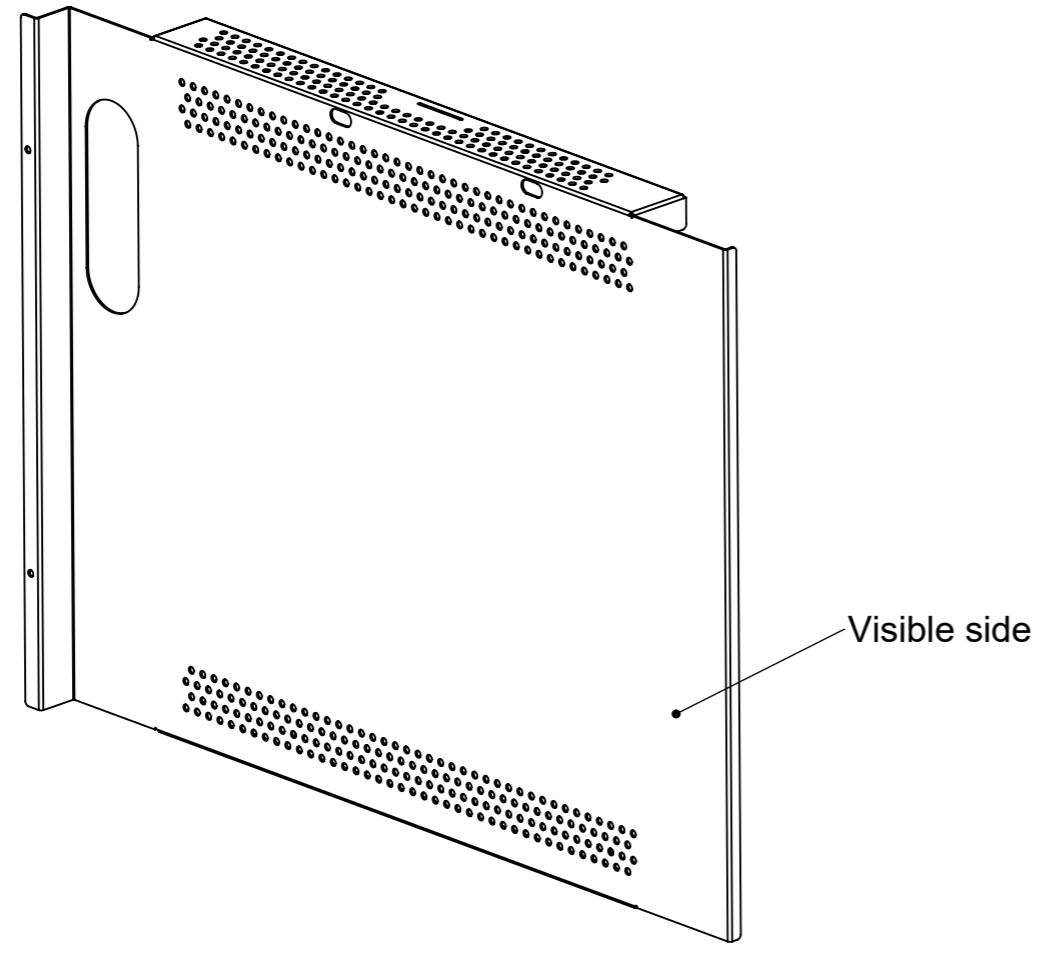

UNLESS OTHERWISE SPECIFIED: DIMENSIONS ARE IN MILLIMETERS SURFACE FINISH: TOLERANCES: LINEAR: ANGULAR:			FINISH: Powder paint, all surfaces RAL7040 Thickness min 50um		DEBUR AND BREAK SHARP EDGES	DO NOT SCALE DRAWING		REVISION B		
DRAWN	MPI		DATE	7.12.2015			TITLE: <b>Enclosure Base, Right</b>			
CHK'D	MPI		DATE	18.1.2016						
APPV'D	-		DATE	-						
MFG										
Q.A					MATERIAL: DC01 Am s=1,5 mm		DWG NO. 32739		A3	
File:			Navaia_Enclosure_Base			Prod. code: -		SCALE:1:5		SHEET 4 OF 4